

## Application Note

### ML-55-106 for lighting

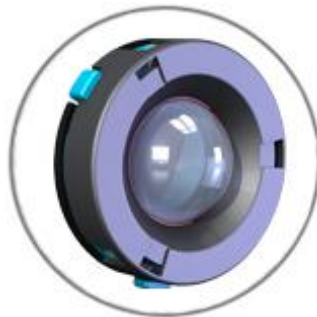

## Introduction

The following application note outlines the design, optics and recommended components to be used for a lighting design with the ML-55-106 Lumilens. Due to the large aperture of 55mm, Optotune will only manufacture the core lens element of the ML-55-106 Lumilens, leaving the housing design and production up to the customer. This allows a design of the housing according to the overall design of a lighting fixture. The necessary CAD files of the actuation mechanism inside the housing are available under NDA on request. With this application note and the CAD designs, it's a simple process to integrate the ML-55-106 Lumilens into a fixture design and to choose the right components for the target performance.

## ML-55-106

The ML-55-106 is delivered as core lens element only, as shown in figure 1.



Figure 1: ML-55-106 core lens element

The lens element involves a container, filled with a liquid and sealed with a thin membrane. A metal ring is glued onto the membrane as shown above. The housing is pushing onto this metal ring when actuating the lens to form a spherical lens.

## Specifications

	<b>ML-55-106-NOC-LD</b>
Dimensions ( $\varnothing$ x thickness)	106mm x 50mm
Clear aperture	55mm
Focal length range (EFL)	From +92mm to infinity
Lens Type	Plano convex
Transmission (visible)	>90%
Refractive Index $n_D$	1.300
Abbe number $V_d$	100
Operating Temperature	-20°C to +80°C

Explanation:

ML: Manually tunable

NOC: No coating

LD: Low dispersion material



## Components – LED & Secondary Optics

### General

In a light design with the ML-55-106 Lumilens, secondary optics are used to collimate the LED light to the desired maximum angle. By tuning the ML-55-106 Lumilens, the spotlight can be tuned from the angle of the secondary optics to a much smaller spot size. In the applications tested so far, we used TIR lenses with a diffuse layer on top. If a reflector is used instead of a TIR lens, it's important to have a diffuse layer on the LED to prevent the imaging of the LED structure when tuning the adaptive lens. Also, the chosen secondary optics in combination with the LED need to have an even distribution of the light intensity for efficient tuning results. Ideal performance is achieved for combinations of LEDs and TIR-lenses with an output diameter of 30mm and FWHM-angles of 35-45°. The performance of the ML-55-106 Lumilens together with LED/TIR-lens combinations that produce smaller offset angles than 35-45° needs to be tested. Corresponding TIR-lenses can be found on the Carclo website (check for lenses of the categories "Frosted Medium" and "Frosted Narrow"). Placing the ML-55-106 Lumilens at larger distances from the TIR-lens might increase the tuning effect, but leads to a reduction in the overall efficiency.

### Examples

- LED Luminus SST-90 with TIR-lens Carclo 10758 "Frosted Wide" – 2200 Lumen – 35° (FWHM)
- Check website of Carclo (<http://www.carclo-optics.com/opticselect/>) for various LED/TIR-lens combinations producing above mentioned FWHM-angles and 30 mm TIR-lens output diameters.

## Design & Optics

### General

For the design of the housing, which is actuating the core lens element, CAD files are available. With them, you can design the housing according to your fixture design. To tune the lens, the housing moves against the core lens element, pressing the metal ring on the elastic surface against the housing, causing a lens to form. The travel of the core lens element against the housing from the plane stage to the fully tuned stage is **6.5mm**. With this proposed design, a tuning range of  $35^{\circ}$ - $10^{\circ}$  FWHM angle will be achieved with an aperture of 55mm. Placing the ML-55-106 Lumilens at larger distances from the TIR-lens might increase the tuning effect, but leads to a reduction in the overall efficiency

### Example

#### LED Luminus SST-90 with TIR-lens Carclo 10758 "Frosted Wide" – 2200 Lumen – $35^{\circ}$ - $10^{\circ}$ (FWHM)

Below is a mechanical design proposal of the LED, TIR lens and the adaptive condenser lens. In this proposal, the travel is achieved through rotation of the housing, which through an inclininator causes an axial travel of 6.5mm against the core lens element. However, it is up to the customer how to achieve the necessary 6.5mm axial travel in a housing design.

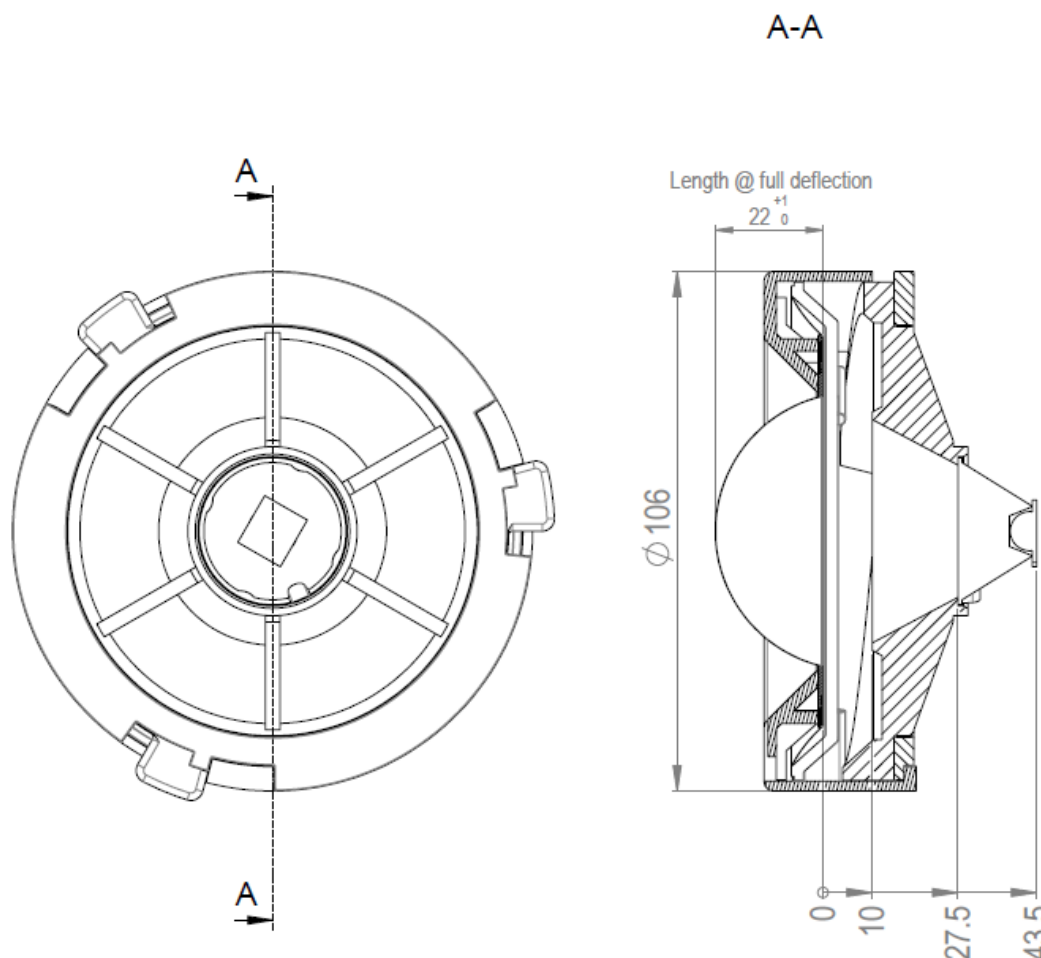

## Color transmission

Due to the high Abbe number of the adaptive lens fluid, there are no chromatic aberrations. This could be confirmed in several measurements which showed no color errors at the edge of the spot.

However, if the LED has a large phosphor coating over the whole chip (ex. LedEngin), the coating is imaged in the fully tuned state and causes a color error.

With a chip that has only a phosphor coating on the single LED and not the whole chip (ex. Cree MC-E), the effect was not observed. See the illustration below:

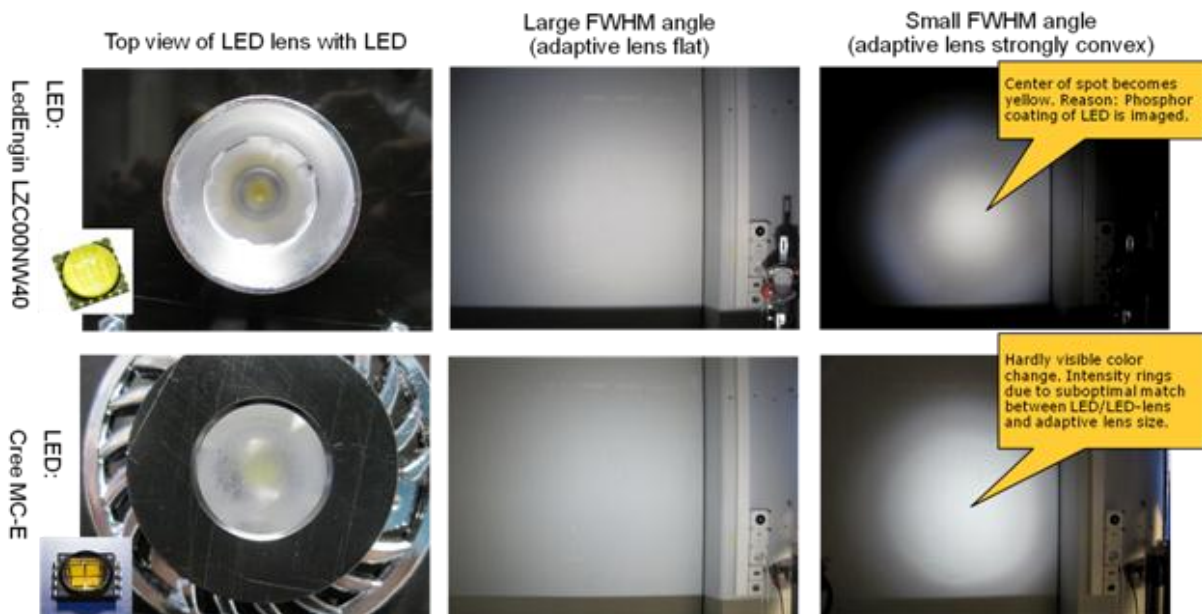

## Further Information & Support

For further information about the design of a lighting system with adaptive optics, or a quote to support you in your applications engineering don't hesitate to contact us at [sales@optotune.com](mailto:sales@optotune.com)